

THE TROF (TOWER REFLECTOR WITH OPTICAL FIBERS): A NEW DEGREE OF FREEDOM FOR SOLAR ENERGY SYSTEMS

Ory Zik, Jacob Karni and Abraham Kribus

Environmental Sciences and Energy Research Dept., Weizmann Institute of Science, Rehovot 76100, Israel,
Tel. +972-8-9343766, Fax +972-8-9344124, cikribus@shemesh.weizmann.ac.il

Abstract — The integration of optical fibers into solar energy systems requires a tradeoff between the cost, attenuation, and a limited flux carrying capability (due to limited Numerical Aperture) on one hand, and the flexibility in light distribution on the other hand. This paper presents a novel approach that minimizes the length of fibers in the system while fully utilizing the flexibility advantage. Optical fibers have been steadily improving and their cost has been declining as a result of the proliferation of their use in communication, and more recently in the lighting industry. The use of fibers in concentrating solar thermal systems has potential advantages of providing unprecedented flexibility in the final concentration and the receiver design. A central receiver system based on the Tower Reflector with Optical Fibers (TROF) is presented as a case study in a comparison between conventional concepts of solar thermal power generation, and new concepts employing optical fibers. New approaches to thermal conversion utilizing the flexibility of a fiber-based system are presented, non-isothermal high temperature receivers and distributed receivers. An approximate performance and cost analysis that assumes mass produced solar-optimized fibers is presented. The effects of system size and several fiber types are discussed. The results show that the use of current optical fibers is not competitive for solar-driven electricity generation systems. The analysis points to research and development directions that could lead to cost-effective TROF and other optical fiber-based systems in the future.

1. INTRODUCTION

Attempts to integrate optical fibers into solar energy systems began in the mid-seventies (Kato and Nakamura, 1976) and continued with the concise work of Cariou et al. in the early 80th (Cariou et al., 1982; Cariou et al., 1985) and others (Khatri et al., 1993; Nakamura et al., 1995; Liang et al., 1997; Peill and Hoffmann, 1997; Feuermann and Gordon, 1998a). However, these attempts have not yet been utilized successfully in major energy consuming applications such as the power generation industry. The reasons can be traced to the high cost of fibers, low numerical aperture (low solar energy concentration in the fiber) of the fibers that were considered, and the absence of receiver technology that can fully utilize the geometrical flexibility of optical fibers to improve the system efficiency. These limitations may be alleviated due to recent advances in fiber technology. Driven mostly by the communication market, the fiber industry has grown significantly during the 90's, leading to a significant reduction in fiber cost and improvement in fiber performance. Recent progress in optical fibers for indoor lighting may also be useful for solar energy, since the requirements for solar energy applications are much closer to those for lighting fibers than to communication fibers. The third issue is addressed by recent developments in a high temperature solar receivers (Karni et al., 1997; Buck et al., 1998), opening the way to benefit from the unique geometrical flexibility of optical fibers. A very different application of fibers with solar energy in medicine was also proposed recently (Feuermann and Gordon, 1998b). However, in this contribution we restrict the discussion to the mainstream application of solar thermal electricity generation.

In concentrating solar energy systems, geometrical constraints are placed on the receiver and other system components to accommodate the optics. The receiver and additional hardware (engine, heat exchangers, etc.) have to be placed in awkward locations, such as on top of a tower, or hanging at the focus of a

dish concentrator. The use of secondary optics near the receiver's aperture introduces additional large components at the same inconvenient location. The receiver's design is constrained to fit the incoming radiation, rather than optimized, for example, to achieve the best convective heat transfer. Replacing transmission through air by transmission through optical fibers may offer an inherent geometrical flexibility that can open possibilities for new solar energy concepts. On the other hand, fibers add to the total cost of the system, and are less transparent than air. Although some of the modern optical fibers are very transparent across the solar spectrum, they are still an absorbing medium, and the attenuation loss can be significant when transporting radiation over large distances. It is therefore not clear then whether the use of optical fibers in a solar energy system can provide a net advantage relative to conventional solar designs.

A principal requirement for the success of a solar-fiber system is maximizing the benefits of the geometrical freedom that the fibers allow, while minimizing the length of fibers in the system. Minimizing the fiber length is necessary to keep the two penalties, attenuation and cost, sufficiently low to be compensated by cost reduction due to the geometrical flexibility. We therefore consider systems with centralized generation (central receiver), where most of the optical path is in air, and only the final concentration step and the interface to the receiver are performed using optical fibers. Three system configurations are compared: a tower-top system, with a fiber concentrator/distributor replacing the traditional secondary concentrator; a Tower Reflector with Optical Fibers (TROF), which will be described below; and as a reference case, a non-fiber Solar Concentration Off Tower (SCOT) system with a CPC array at the lower focus (Kribus et al., 1998). This complements a previous analysis of solar/fiber options (Kribus et al., 1999) which compared the tower-top option to a 'mini-dish' field (Feuermann and Gordon, 1998a) and to several options of dish-engine systems.

The total cross-section of the fibers in the system is proportional to the system's rated power, which scales with the square of the radius of the primary collector. The length of the fibers is proportional to the primary collector radius even when the fibers are used only as the last optical step, since the size of the field's target is proportional to the size of the primary field. The total volume of the fibers, and hence the material cost, is then proportional to the cube of the collection radius, and grows faster than the collected power. Attenuation loss is also proportional to the length of the fibers and also increases with the collection radius. It is therefore obvious that unless fiber cost and attenuation become negligibly small, only very small systems with fibers may be viable. The systems analyzed below are therefore small, sub-megawatt plants such as described in (Kribus et al., 1998).

We first present a conceptual view of how the optical fibers can be integrated into a central receiver system, and possible new approaches to the design of appropriate central receivers. The aforementioned three system options are then presented, followed by a first-order system-level performance and cost analysis. The overall solar-to-electricity conversion efficiency and the system's specific cost ($\$/kW_e$) are computed for each system, as a function of system size. The results are then presented and discussed, showing a comparison between the conventional and fiber-based systems, and also discussing other options for fiber-based solar generation systems.

2. NOVEL COMPONENTS

2.1. A Fiber Light Distributor

The fiber distributor subsystem accepts the concentrated radiation from the primary optics, a heliostat field in our case. The distributor then guides the radiation to the receiver, providing the final concentration stage and the interface to the receiver, instead of the more familiar non-imaging secondary concentrator. A schematic presentation of the distributor is shown in Figure 1. The entrance plane of the distributor may contain small dielectric concentrators, made from the same material as the fibers, which guide the light into the individual fibers. These concentrators can compensate for the difference between the rim angle of the primary collector and the acceptance angle of the fiber; such a difference may exist since the primary could be optimized based on overall system performance and cost, and not constrained to provide the necessary rim angle. It is also convenient to have this additional concentration stage since it creates a space between fibers which makes handling and installation easier. If desired, the exit of the fiber into the receiver can also contain a small dielectric concentrator that brings the flux to the maximum permitted by the available angular range (Feuermann and Gordon, 1998a).

In a previous analysis (Kribus et al., 1999) we considered several existing fibers as candidates for solar applications. Two of these were selected as most appropriate. The Schott W fiber has an exceptionally high Numerical Aperture (0.86), and therefore can carry a relatively high flux. This fiber has, however, a fairly high attenuation over the solar spectrum (2.3 dB/m), and can be used only over a short optical path. Spectran's HCN-H1000T has a lower NA (0.48), but much lower attenuation (0.35 dB/m), and is therefore much better suited for longer optical paths. In addition to these two existing

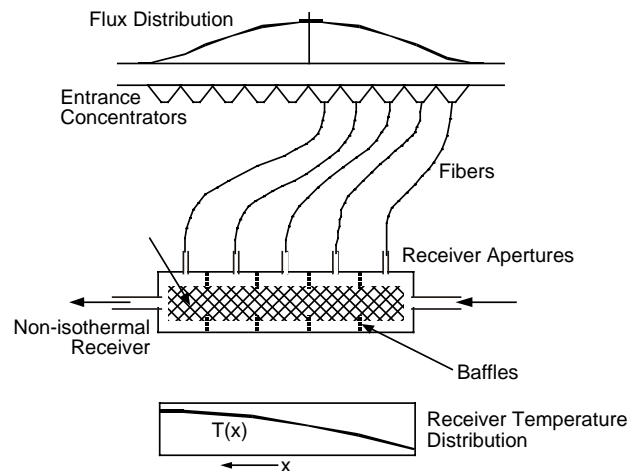

Figure 1. Fiber distributor and non-isothermal receiver for concentrated solar energy. Top: non-uniform flux distribution incident on the target of the primary collector. Bottom: temperature distribution along the receiver.

fiber types, we also consider a hypothetical fiber that has the same low attenuation as the Spectran model, and $NA=1$. Such a fiber would be made of a silica core without cladding (Cariou et al., 1985; Feuermann and Gordon, 1998a), utilizing the large difference in index of refraction between silica and air. We use this hypothetical fiber as an upper bound on the potential performance of real fibers. In the analysis below, we consider and compare these three fiber types.

Commercial mass-produced communications fibers have fairly low cost, typically a few cents per linear meter. However, fibers suitable for solar applications, having large diameter, high NA and low attenuation, are currently not mass produced and therefore their cost is much higher. We assume solar-optimized fibers that are produced on a large scale using techniques similar to those in use for communications fibers today. In communication fibers, the cost is dominated by the production process, and the material accounts for a small fraction only (around 10%). For thick solar fibers, we assume that the production cost per unit length is about the same as thin fibers, but the amount of material is much higher. Based on such an extrapolation and the current cost of silica, we estimate that mass production and competition could drive the solar fiber cost to the range of $\$0.2$ – $0.5/\text{m}$ for 1 mm diameter fibers. In the following sections we use the lower cost of $\$0.2/\text{m}$ as a reference estimate.

2.2. A Non-isothermal Receiver

The conventional design for a high-temperature solar receiver is a cavity with a relatively small aperture allowing entrance of concentrated sunlight. An absorber element is arranged in some compact geometry (e.g., hemispheric, annular, cubic) around the aperture such that the concentrated light is dispersed more or less evenly on all absorber surfaces (Buck et al., 1996; Karni et al., 1997). This design is not necessarily optimal for heat transfer, but is dictated by the nature of the radiation incident through the aperture. An attempt to improve the convective heat transfer and match it to the available flux distribution is the partitioned receiver concept (Ries et al., 1995), where the aperture is divided into several receivers operating at different

temperatures. However, a straightforward implementation of this idea using conventional receivers and secondary concentrators (Doron and Kribus, 1996) can be quite cumbersome. The inherent geometric flexibility of the fiber distributor permits a new implementation of the non-isothermal receiver concept.

We propose a receiver as an essentially tubular vessel with flow along its axis, and the fiber inlet apertures positioned on the external walls (Figure 1). The radiation flux carried within each fiber depends on the position of its entrance aperture within the primary concentrator's target plane. At the receiver side, the fiber exit apertures are distributed such that those providing low flux are installed near the fluid inlet, and those carrying the highest flux are installed near the fluid exit. This is the optimal match of temperature and incident flux as shown in (Ries et al., 1995). Heat transfer by thermal emission between regions of different temperatures is minimized due to the large length-to-diameter ratio of the receiver, which provides a very small view factor among sections having different temperatures. If necessary, internal baffles may be installed to further suppress lateral heat transfer (Figure 1).

2.3. Distributed receiver system

Using a fiber distributor as the final concentrator provides a degree of freedom not possible in previous solar designs. In current solar plant designs, the radiation is concentrated and used in a single receiver unit located at the focal region. Even a partitioned receiver system (Doron and Kribus, 1996) is still constrained to the same physical location since it is connected to an array of secondary concentrators, and the distance among receiver stages must be minimal to reduce thermal and pressure losses in the connecting pipes. The so-called "distributed receiver" used in line-concentrating systems is also, in fact, a single receiver constrained to a linear focus rather than a point focus. By using optical fibers, however, we open the possibility of a truly distributed receiver. We can channel parts of the fiber bundle to different locations, and operate separate receivers that are independent and functionally parallel to each other.

This new degree of freedom can be used for novel applications that are not accessible with a single receiver. For example, many of the gas turbines available today have a distributed, multi-chamber combustor: the compressed air is distributed to separate combustion chambers located around the circumference of the turbine. These turbines cannot be integrated with a standard solar plant, which requires all the compressed air to be available in a single external duct. Using a distributed receiver system, we can construct many small receivers, one for each combustion chamber, and channel a portion of the optical fiber bundle to each receiver (Figure 2). The fiber distributor provides then access to gas turbines that were previously not compatible with solar energy applications.

3. SYSTEM OPTIONS

3.1. Tower-Top Fiber System

The primary optics of this system is a heliostat field with a central tower. On top of the tower, however, the light is intercepted by a fiber distributor with its inlet aperture at the field's aim point, as shown in Figure 3(a). The concentrated light collected into the fibers is guided to a non-isothermal

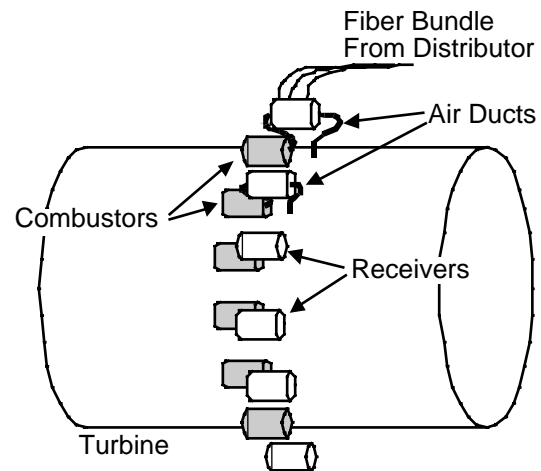

Figure 2. Distributed receiver system for a gas turbine with a distributed annular combustor. Each combustor is preceded with a separate receiver, and each receiver is supplied with a separate fiber bundle.

receiver installed nearby on the tower. A small gas turbine completes the electricity generation plant. The fiber distributor replaces the standard secondary concentrator, and provides the final step of concentration and the interface to the receiver. The potential advantages of this arrangement relative to traditional tower-top systems are the elimination of a large secondary concentrator, a more flexible design of the receiver, and easier access to the receiver which can be placed away from the focal area.

In order to analyze the performance and cost of the tower-top system, we make the following assumptions:

- Solar half-angle, including primary mirror errors, is 7 mrad; direct insolation is $1,000 \text{ W/m}^2$. The sun is assumed to be at the zenith, and the resulting performance is therefore the best design-point value rather than annual average.
- The heliostat field layout produces ground coverage (reflector aperture area divided by ground area) of 0.33; the field is circular with the tower in the center. The heliostats are arranged such that blocking is minimized.
- Collection radius at the target plane is designed close to maximum efficiency (4% spillage assumed); the effect of heliostat astigmatism is accounted for by increasing the collection radius by 20% relative to the focal spot created by infinitesimal heliostats..
- The field rim angle is limited by the fiber's acceptance angle; if it is less than the fiber's acceptance angle, a dielectric secondary concentrator is used at the entrance to each fiber.
- Fiber length is three times the radius of the focal spot, to account for distance to receiver and guiding to the receiver inlet ports.
- The fiber is one of: (1) Schott W; (2) Spectran HCN-H1000T; or (3) the hypothetical fiber with $NA=1$ and attenuation the same as (2). Fiber entrance and exit transmission is 0.94 and 0.96, respectively.
- The receiver heats gas to 900°C , suitable for a small gas turbine; absorber maximum temperature for emission loss is $1,100^\circ\text{C}$.

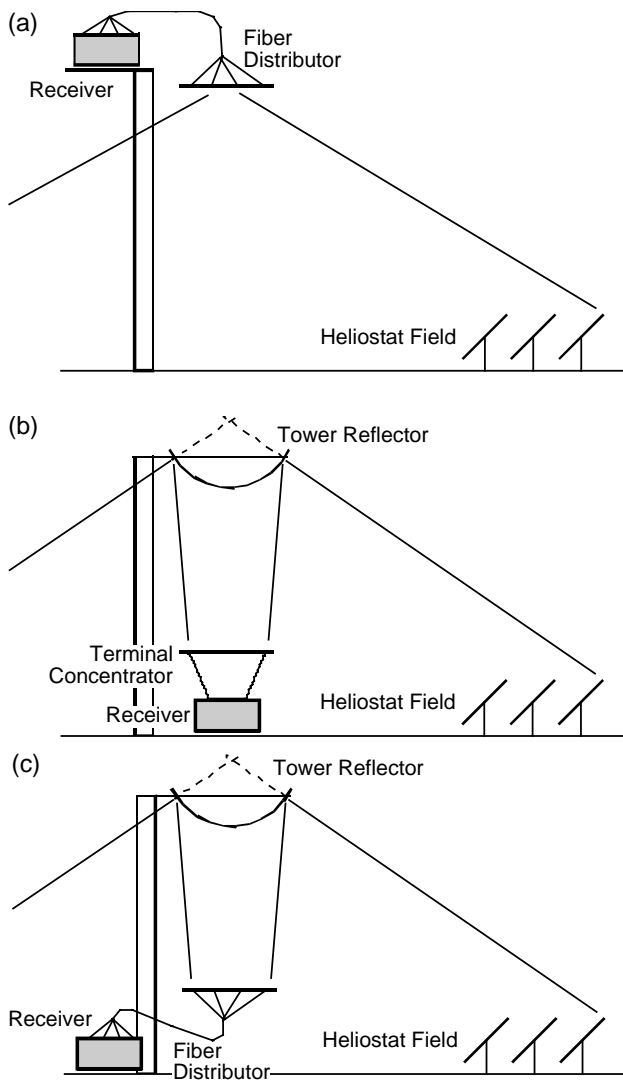

Figure 3. Three system designs: (a) Tower-top, (b) SCOT, and (c) TROF.

- The Power Conversion Unit efficiency is 30%, representative of a recuperated Brayton cycle (gas turbine); we assume that the efficiency is independent of turbine size.
- Heliostats cost is \$250/m². Fiber cost is \$0.2/m (1 mm diameter silica fibers), assuming extensive competition and mass production. Receiver cost is \$200/kW_{th}. Power Conversion Unit (PCU) is \$600/kW_e. Tower cost is assumed to vary linearly with height at \$2,500/m up to 30 m height; above 30 m, the dependence is exponential: $\text{Cost} = C_1 \cdot e^{C_2 \cdot \text{Height}}$. Fixed costs (including master control) are \$10,000 plus 2% of the other components' cost. Indirect costs add 20%.

Tower height is optimized to provide the lowest specific plant cost, \$/kW_e, subject to the constraint that the field rim angle is not larger than the fiber acceptance angle. The optimization is repeated for several values of the field radius.

3.2. SCOT system

We consider this non-fiber system as a reference to the other cases. The Solar Concentration Off-Tower (SCOT) system was described in (Kribus et al., 1998) based on the 'Reflective Tower' Cassegrainian optics (Rabl, 1976). A hyperboloid reflector on top of the tower projects the concentrated radiation on a lower focal plane, where it is intercepted by an array of non-imaging terminal concentrators and corresponding receivers, as shown in Figure 3(b). In analyzing this system we used the same assumptions as in the previous section, with the following additions:

- The reflectivity of the TR and the terminal concentrators is 0.97.
- The cost of the Tower Reflector is \$1,500/m² (more expensive than heliostats due to structural requirements and higher quality reflectors); the cost of the terminal concentrators is \$3,000/m² (due to active water cooling, high quality reflectors, and frequent maintenance requirements).

Two parameters are free for optimization in this system: the height of the heliostat aim point (the hyperboloid upper focus), and the hyperbola magnification (the ratio of the two focal lengths). These two parameters were optimized to produce the lowest specific cost. This optimization was repeated for several values of the field radius.

3.3. TROF System

In the TROF (Tower Reflector Optical Fiber) concept, the terminal concentrators of the SCOT system are replaced with a fiber distributor, and the partitioned receiver array is replaced with a single non-isothermal receiver, as shown in Figure 3(c). The assumptions for performance and cost are consistent with the previous cases. Two parameters are optimized to produce the lowest specific cost, as for the SCOT system: the aim point height and the hyperbola magnification. The rim angle of the hyperboloid as seen from the distributor inlet aperture was constrained to be less than the acceptance angle of the fibers. However, this constraint was not activated since this rim angle is usually fairly small for a reasonable magnification of the hyperbola. The optimization was repeated for several values of the field radius.

4. RESULTS

In the following sections we present and compare the performance and specific cost of the three different system options. We estimate the efficiency of conversion from solar to electricity under nominal conditions (design-point efficiency), and the specific cost per kilowatt of rated generation capacity. The competitive range for power production, according to current market conditions, is roughly in the range of \$2,000—3,000/kW_e for on-grid large-scale power production, and \$4,000—8000/kW_e for remote, off-grid applications. Since a solar plant with optical fibers is limited in size, as noted above, we focus primarily on suitability for the off-grid market. A more detailed analysis could consider other criteria such as Levelized Energy Cost, but this would require a higher level of detail which we did not attempt in this work.

A comparison of overall conversion efficiency is shown in Figure 4. Each point represents separately optimized plant, as explained above. In all cases, using the high NA, high

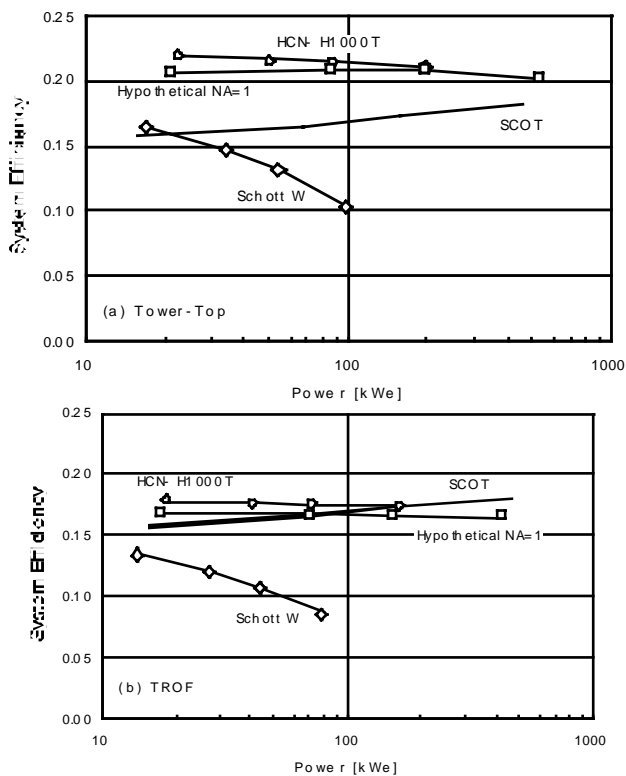

Figure 4. Overall conversion efficiency of (a) the Tower-Top and (b) the TROF systems, compared to the non-fiber SCOT system, as a function of plant rated power. The results are shown for the three types of fibers.

attenuation Schott fiber yield significantly lower efficiency, as expected. The Tower-Top system has higher efficiency than the SCOT system, since it incurs less reflection losses; the losses in the TROF and SCOT systems are similar, as the fiber distributor replaces the conventional terminal concentrators.

The specific cost for the three system design options are shown in Figure 5. The SCOT system shows the lowest specific cost in all cases, and the trend shows decreasing specific cost as system size increases. All systems with a fiber distributor show a minimum specific cost at some size, and rapidly increasing cost as the system size increases beyond the optimum point. This is consistent with our observation that the cost of a fiber system increases faster than the rated power when system size is increased. The specific cost for the Tower-Top and TROF systems with real fibers are significantly higher than the SCOT system, and are close to the high end of the competitive range. The assumption of the hypothetical fiber yields a significant reduction in the specific cost relative to the real fibers, but the values are still higher than the SCOT system. At the plant size corresponding to the minimum cost, the specific cost of the Tower-Top system is about 27% higher than the SCOT system at similar plant size. The same comparison for the TROF system shows a difference of about 14% relative to the SCOT system at the optimal point. The TROF system is then preferable to the Tower-Top system, but still not competitive relative to the conventional SCOT system.

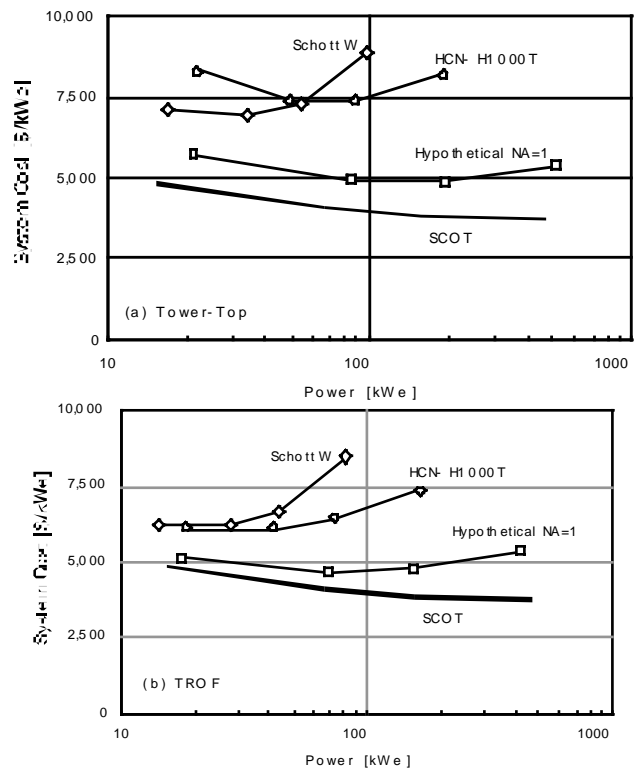

Figure 5. Plant specific cost of (a) the Tower-Top and (b) the TROF systems, compared to the non-fiber SCOT system, as a function of plant rated power. The results are shown for the three types of fibers.

5. DISCUSSION

A disadvantage of 14% in specific cost, as shown for the TROF system compared to the conventional SCOT design, is probably not significant in view of the approximate nature of the present analysis. We did not intend to make definite statement about the feasibility of fiber-based systems in the near future. Rather, the main conclusion that we may draw from this comparison points to the advances that are required before a fiber-based system such as the TROF can be considered in a competition against conventional concentrating systems. Two main assumptions were required in our analysis: one is a low cost of the fibers (we assumed \$0.2/m for 1 mm diameter silica fibers, which is significantly below the current cost); and the second requirement is a significant increase in performance (we assumed NA=1, the upper limit which is not achieved in existing low-attenuation fibers). If these two assumptions can be realized, then a fiber-based system may become competitive. Further research and development of the use of optical fibers with concentrated solar energy should then address these two issues of performance and cost.

A key feature in any solar fiber-based system is minimizing the amount of fibers used in the system, since they are a significant cost driver. This implies that fibers should be used only for a small part of the optical path, for example for the final concentration stage as shown here. Furthermore, maximum utilization should be made of the inherent flexibility that the fibers offer: examples are development of non-isothermal

receivers that exploit the non-uniform intensity distribution at the focus of the primary optics, and novel approaches to distributed receiver systems that may enable new applications for concentrated solar energy.

Fiber-based central systems such as the TROF could be relevant, according to the results for the specific cost, in a range of system sizes between 20 and 100 kW_e. This range is traditionally allocated to a different class of solar plants, dish-engine systems. In a previous analysis (Kribus et al., 1999) we have compared several dish-engine systems, with and without a fiber component, under assumptions similar to the present analysis. The results of that analysis showed that a fiber distributor based dish system can provide an advantage over conventional dish-engine systems, yielding specific costs of less than \$4,000/kW_e. This can compete favorably against the small SCOT system shown here. The conclusion is then that the most attractive candidate from the variety of fiber-based options is probably a dish-engine rather than a small solar tower system.

REFERENCES

- Buck, R., Abele, M., Kunberger, T., Denk, T., Heller, P. and Lüpfer, E. (1998). Receiver for solar-hybrid gas turbine and combined cycle systems. *9th Intl. Symp. Solar Thermal Concentrating Technologies*, Odeillo, EDP Sciences.
- Buck, R., Heller, P. and Koch, H. (1996). Receiver Development for a Dish-Brayton System. *ASME International Solar Energy Conference*.
- Cariou, J. M., Dugas, J. and Martin, L. (1982). Transport of solar energy with optical fibers. *Solar Energy* **29**: 397–406.
- Cariou, J. M., Dugas, J. and Martin, L. (1985). Theoretical limits of optical fibre solar furnaces. *Solar Energy* **34**: 329–339.
- Doron, P. and Kribus, A. (1996). Receiver partitioning: a performance boost for high-temperature solar applications. *8th Int. Symp. Solar Thermal Concentrating Technologies*, Köln.
- Feuermann, D. and Gordon, J. M. (1998a). Solar fiber-optic mini-dishes: a new approach to the efficient collection of sunlight. *Solar Energy* **65**: 159–170.
- Feuermann, D. and Gordon, J. M. (1998b). Solar surgery: remote fiber optic irradiation with highly concentrated sunlight in lieu of lasers. *Optical Engineering* **37**: 2760–2767.
- Karni, J., Kribus, A., Rubin, R., Sagie, D., Doron, P. and Fiterman, A. (1997). The DIAPR: a high-pressure, high-temperature solar receiver. *Journal of Solar Energy Engineering* **119**: 74–78.
- Kato, D. and Nakamura, T. (1976). Application of optical fibers to the transmission of solar radiation. *J. Applied Physics* **47**: 4528–4531.
- Khatri, N., Brown, M. and Gerner, F. (1993). Using fiber optics to tap the sun's power. *Int. Comm. Heat Mass Transfer* **20**: 771–781.
- Kribus, A., Zaibel, Z., Segal, A., Carey, D. and Karni, J. (1998). A solar-driven Combined Cycle plant. *Solar Energy* **62**: 121–129.
- Kribus, A., Zik, O. and Karni, J. (1999). Optical fibers in Solar Energy. *Solar Energy*: Submitted.
- Liang, D., Nunes, Y., Monteiro, L. F., Monteiro, M. L. F. and Collares-Pereira, M. (1997). 200 W solar energy delivery with optical fiber bundles. *Nonimaging Optics: Maximum Efficiency Light Transfer IV*.
- Nakamura, T., Senior, C. L., Shoji, J. M. and Waldron, R. D. (1995). Optical waveguide solar energy system for lunar material processing. *Proc. ASME Solar Engineering Conf.*
- Peill, N. J. and Hoffmann, M. R. (1997). Solar-powered photocatalytic fiber-optic cable reactor for waste stream remediation. *J. Solar Energy Engineering* **119**: 229–236.
- Rabl, A. (1976). Tower reflector for solar power plant. *Solar Energy* **18**: 269–271.
- Ries, H., Kribus, A. and Karni, J. (1995). Non-isothermal receivers. *Journal of Solar Energy Engineering* **117**: 259–261.